

APPROVED TAPPING METHOD

TOP VIEW

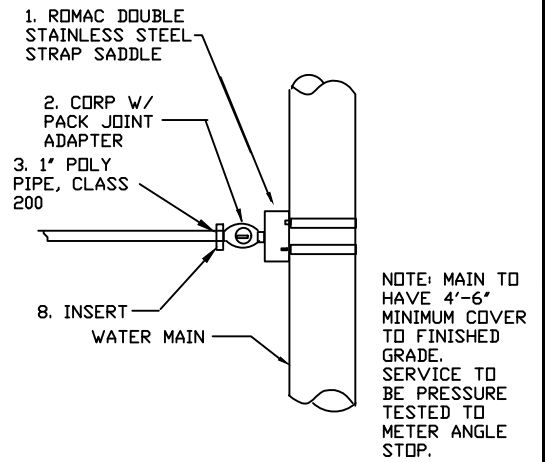

SIDE VIEW

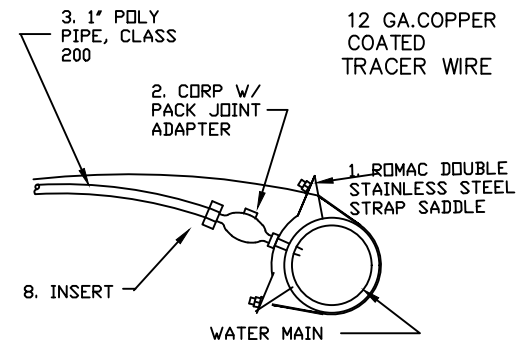

SIDE VIEW

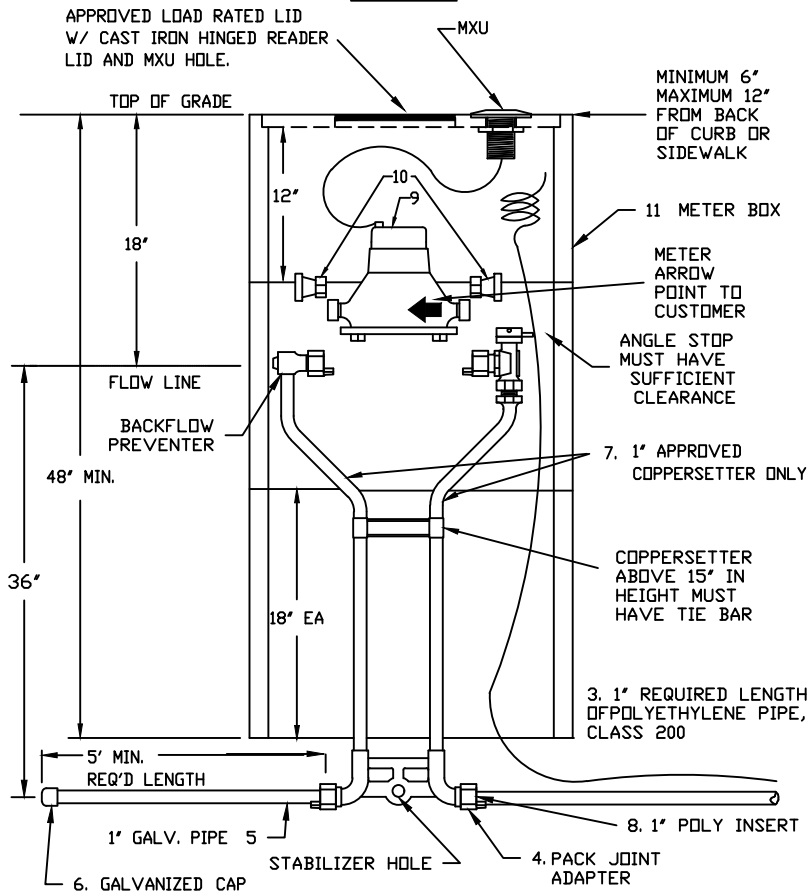

APPROVED TAPPING METHOD AND PARTS

ITEM NO.	NO. REQ'D.	DESCRIPTION
1	1	1" ROMAC DOUBLE STRAP SERVICE SADDLE
2	1	1" x 1" POLY PACK JOINT BRONZE CORPORATION STOP.
3	1	1" x REQ. LENGTH - USE PIPE SIZE, 200 PSI POLYETHYLENE SERVICE LINE
4	1	1" IPS x 1" POLY BRASS PACK JOINT ADAPTER
5	1	1" x MIN 5' LONG - GALVANIZED IRON PIPE BACK SIDE
6	1	1" GALVANIZED CAP.
7	1	1" APPROVED NSF 61 COMPLIANT COPPERSETTER, ALL COMPONENTS
8	2	1" POLY INSERTS WHERE NEEDED
9	1	3/4" BADGER RADIO READ METER (METER LAY LENGTH=7 1/2")
10	2	#24 ADAPTERS
11	3	ARMORCAST 13X24 RPM OR HUBBEL/QUASITE 1130 BOX W/ RADIO READ LID AND HINGED CAST IRON READER LID. BOX WILL CONSIST OF 18" BOTTOM AND MIDDLE SECTIONS, 12" TOP SECTION.

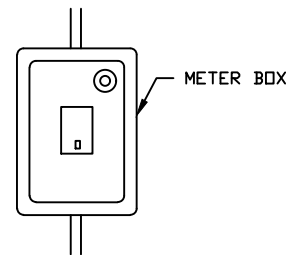

PLAN VIEW

NOTE: ALL MATERIALS USED IN CONTACT WITH POTABLE WATER ARE TO BE NSF-61 COMPLIANT.

NOTE: STABILIZER BAR MUST BE USED FOR SETTINGS HAVING POLYPIPE ON BOTH FRONT AND BACK SIDES.

** NOTE: NO PRIVATE CONNECTIONS OR FITTINGS ALLOWED INSIDE THE METER BOX.**
NOTE: POLY PIPE MAY BE USED WHEN CONNECTING TO AN EXISTING SERVICE WHEN A GALVANIZED CONNECTION CANNOT BE EASILY MADE.

REVISION	APPROVED	DATE	CITY OF COEUR d'ALENE STANDARD DRAWING	APPROVED BY:
			1" COPPERSETTER STANDARD PIT SETTINGS	<i>Chris Boddy</i> 4/13/13
				CITY ENGINEER, PE 10804 DATE:
			DWG NO.	W-1