

2018 IRC: SECTION R3021.1 (IDAHO AMENDED CODE)

FIRE RATING OF EXTERIOR WALLS AND PROJECTIONS LESS THAN 3' FROM PROPERTY LINE

TO BE USED FOR DWELLINGS AND ACCESSORY BUILDINGS

1 HOUR FIRE RATING GENERIC ASSEMBLIES: PER THE GYPSUM ASSOCIATION—FIRE RESISTANCE/
SOUND CONTROL DESIGN MANUAL: WP8105 & 2018 IRC SEC R302 OR "EQUIVALENT"

— EXTERIOR SIDE:

ONE LAYER 48" WIDE 5/8" TYPE "X" GYPSUM SHEATHING APPLIED PARALLEL TO 2x4 WOOD STUD 24"o.c. W/1 3/4" GALVANIZED ROOFING NAILS 4"o.c. AT VERTICAL JOINTS AND 7"o.c. AT INTERMEDIATE STUDS AND TOP AND BOTTOM PLATES. JOINTS OF GYPSUM SHEATHING MAY BE LEFT UNTREATED. EXTERIOR CLADDING TO BE ATTACHED THROUGH SHEATHING TO STUD.

NOTE: FASTNER LENGTH SHALL BE INCREASED TO THE THICKNESS OF THE WALL SHEATHING (OSB) AND FASTENED INTO EACH WALL STUD.

— INTERIOR SIDE:

ONE LAYER 5/8" TYPE "X" GYPSUM WALLBOARD, WATER-RESISTANT GYPSUM BACKING BOARD, OR GYPSUM VENEER BASE APPLIED PARALLEL OR AT RIGHT ANGLES TO STUD W/6d COATED NAILS, 1 7/8" LONG, 0.0915" SHANK, 1/4" HEADS, 7"o.c. (**LOAD BEARING**)

****NOTE:**

— FOUNDATION VENTS ARE PERMITTED .

— WATER CAN NOT SHED ONTO NEIGHBORING PROPERTIES

7/16" O.S.B. SHEATHING
INSULATION BAFFLE, MAINTAIN 1" AIR SPACE ABOVE BAFFLE

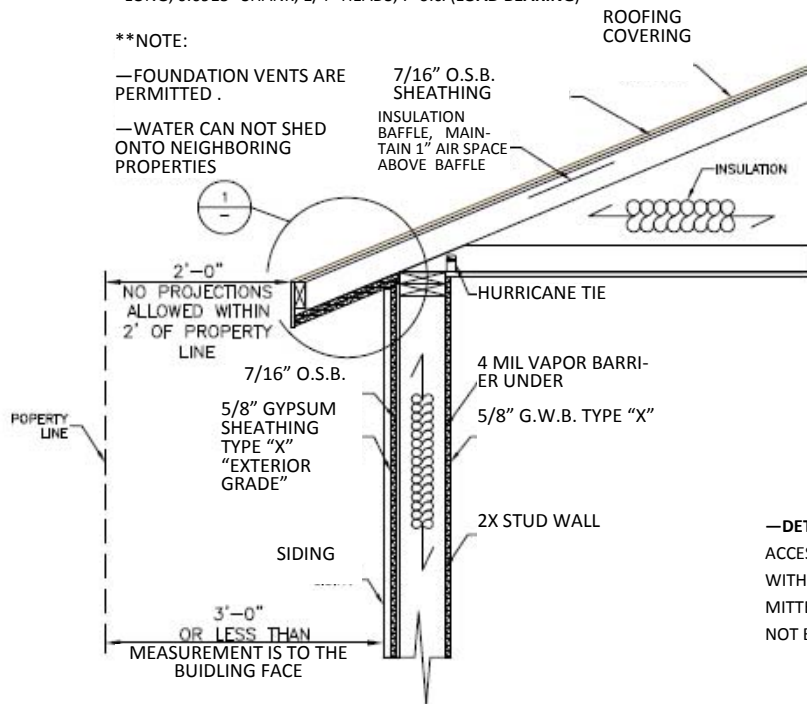

—NOTE
AT EAVES, ONE LAYER IS ALLOWED WHEN THE DISTANCE BETWEEN THE FACIA AND LEDGER IS 16" OR LESS. ALL EDGES SHALL BE BLOCKED AND NAILED 12"o.c. WITH 1 3/4" ROOFING NAILS (THIS INCLUDES SEAMS) THE DOUBLE LAYER SYSTEM NAILING IS ALLOWED TO BE 24"o.c. ON THE FIRST LAYER INSTEAD OF 12"o.c.

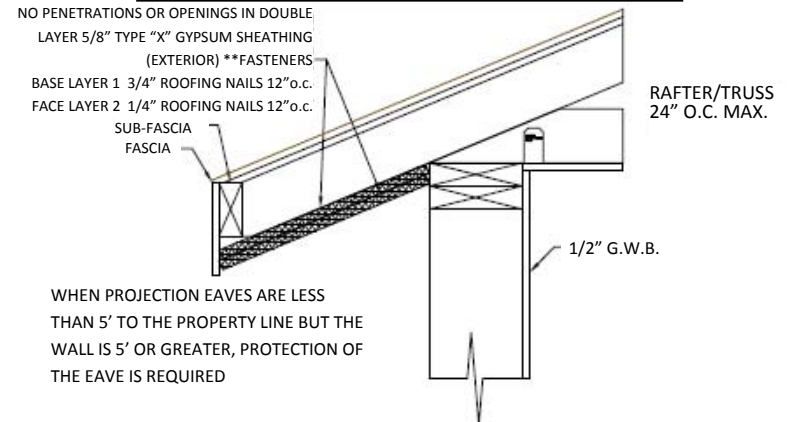

WHEN PROJECTION EAVES ARE LESS THAN 5' TO THE PROPERTY LINE BUT THE WALL IS 5' OR GREATER, PROTECTION OF THE EAVE IS REQUIRED

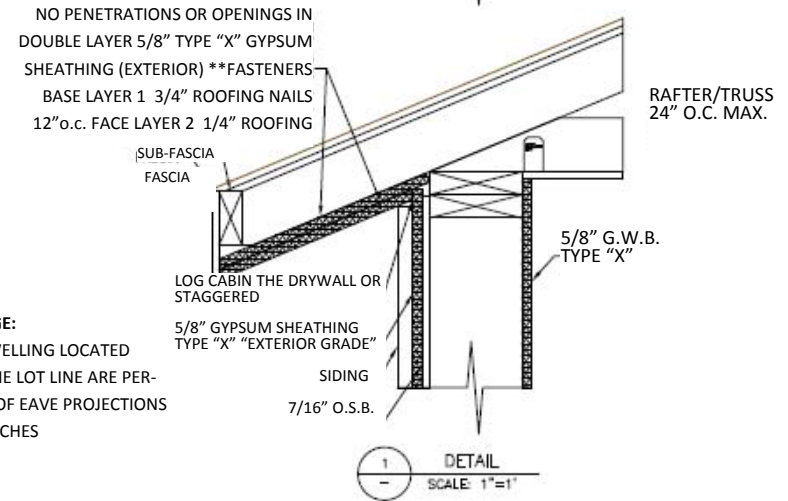

—DETACHED GARAGE:
ACCESSORY TO A DWELLING LOCATED WITHIN 2 FEET OF THE LOT LINE ARE PERMITTED TO HAVE ROOF EAVE PROJECTIONS NOT EXCEEDING 4 INCHES