

**PLAN VIEW**

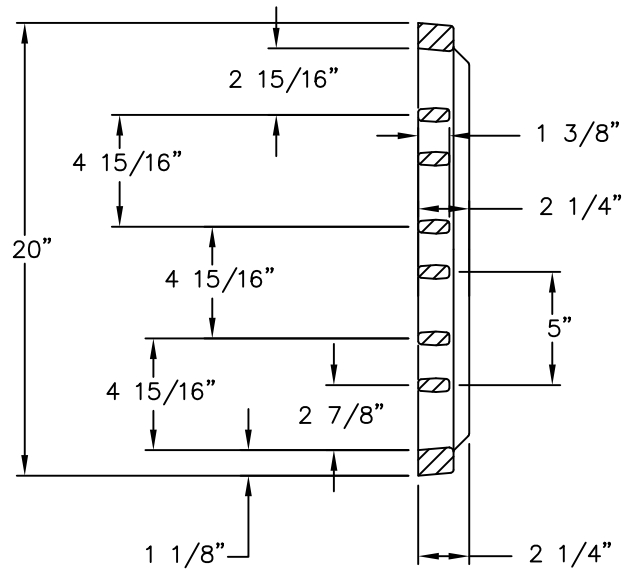

**SECTION VIEW**

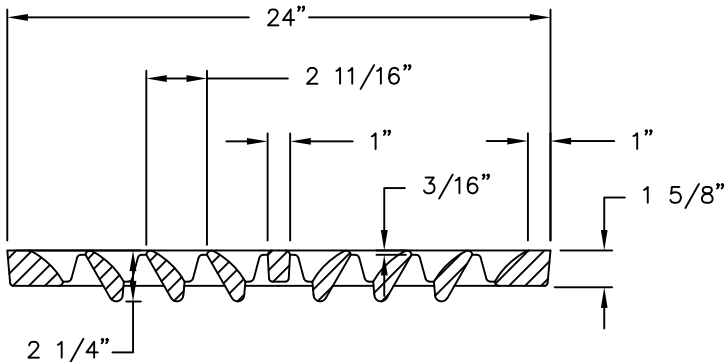

**SECTION VIEW**

**GENERAL NOTES**

1. THE NAME OF THE MANUFACTURER AND DIRECTION OF FLOW SHALL BE EMBOSSED ON THE TOP SURFACE OF EACH GRATE. LETTERING TO BE RECESSED 1/16".
2. FRAME SHALL BE GRAY IRON CONFORMING TO A.S.T.M. A48-90, GRADE 30. THE GRATE SHALL BE DUCTILE IRON CONFORMING TO A.S.T.M. A536-84 GRADE 80-55-06.
3. DIMENSIONS SHALL HAVE  $\pm 1/16$ " TOLERANCE, EXCEPT AS NOTED.
4. EDGES SHALL HAVE 1/8" RADIUS, 1/8" CHAMFER OR COMPLETE DEBURRING.
5. THE FRAME SHALL BE MANUFACTURED IN ACCORDANCE WITH STANDARD FOR TYPE 1 FRAME.
6. WELDING IS NOT PERMITTED.

REVISION	APPROVED	DATE	CITY OF COEUR d'ALENE STANDARD DRAWING	APPROVED BY:
				<p><b>CATCH BASIN GRATE</b> <b>2 - WAY</b></p>
			<p>DWG NO. SD-4A</p>	

6/20/18  
DATE: